

# InSalah CO<sub>2</sub> Storage Project

Project Number:

FWP-FEW0174 Task 2

Principal Investigator:

W. McNab

Team Members:

L. Chiaramonte, S. Ezzedine, W. Foxall, Y. Hao, A. Ramirez, \*J.A. White

## Lawrence Livermore National Laboratory

This work was performed under the auspices of the U.S. Department of Energy by Lawrence Livermore National Laboratory under Contract DE-AC52-07NA27344.

---

U.S. Department of Energy  
National Energy Technology Laboratory  
Carbon Storage R&D Project Review Meeting  
Developing the Technologies and Building the  
Infrastructure for CO<sub>2</sub> Storage  
August 21-23, 2012

# Outline

---

- Benefit to Program
- Project Goals and Objectives
- Technical Status
- Accomplishments
- Summary
- Appendix

# Benefit to the Program

---

- The research project is combining sophisticated modeling tools with multiple monitoring/characterization data sets from an operating field site (InSalah) to address fundamental challenges to successful geologic CO<sub>2</sub> isolation.
- This program meets the Carbon Storage Program goal to “conduct fields tests through 2030 to support the development of BPMs for site selection, characterization, site operations, and closure practices.”

# Project Overview: Goals and Objectives

---

- The project addresses four fundamental challenges to successful CO<sub>2</sub> storage:
  - Modeling of plume migration and prediction of partitioning among various trapping mechanisms
  - Uncertainty quantification of CO<sub>2</sub> distribution within reservoir and potential migration pathways (e.g. damaged caprock).
  - Understanding of fluid-induced seismicity and associated risks.
  - Definition of potential leakage source terms and their impact on a shallow groundwater aquifer.
- Success is tied to ability to reproduce and predict behavior given available monitoring and characterization data, and provide useful guidance for the field operator.

# Technical Status

---

- The research scope consists of four major tasks:
  - Coupled multiphase flow and hydromechanical modeling
  - Stochastic inversion
  - Shallow aquifer geochemistry
  - Induced microseismicity
- A significant portion of this work is focused on understanding anomalous behavior observed in the lower caprock above each injector (today's focus).

# InSalah

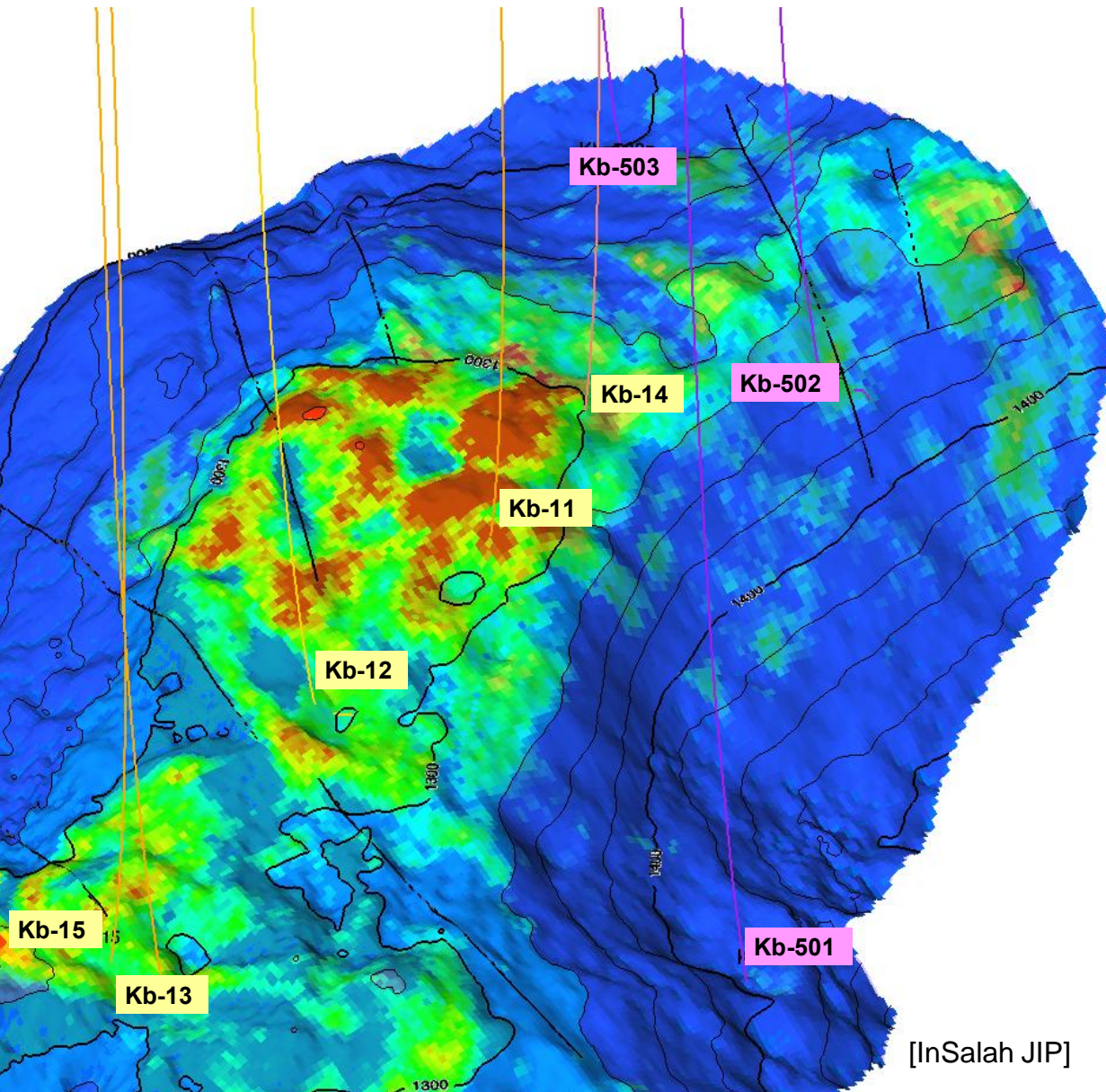

- Reservoir at ~1880m, and ~20m thick
- Anticlinal structure
- Producing gas from the cap
- Re-injected CO<sub>2</sub> at three horizontal wells on limbs

# InSalah

- Stratigraphic summary [InSalah JIP]

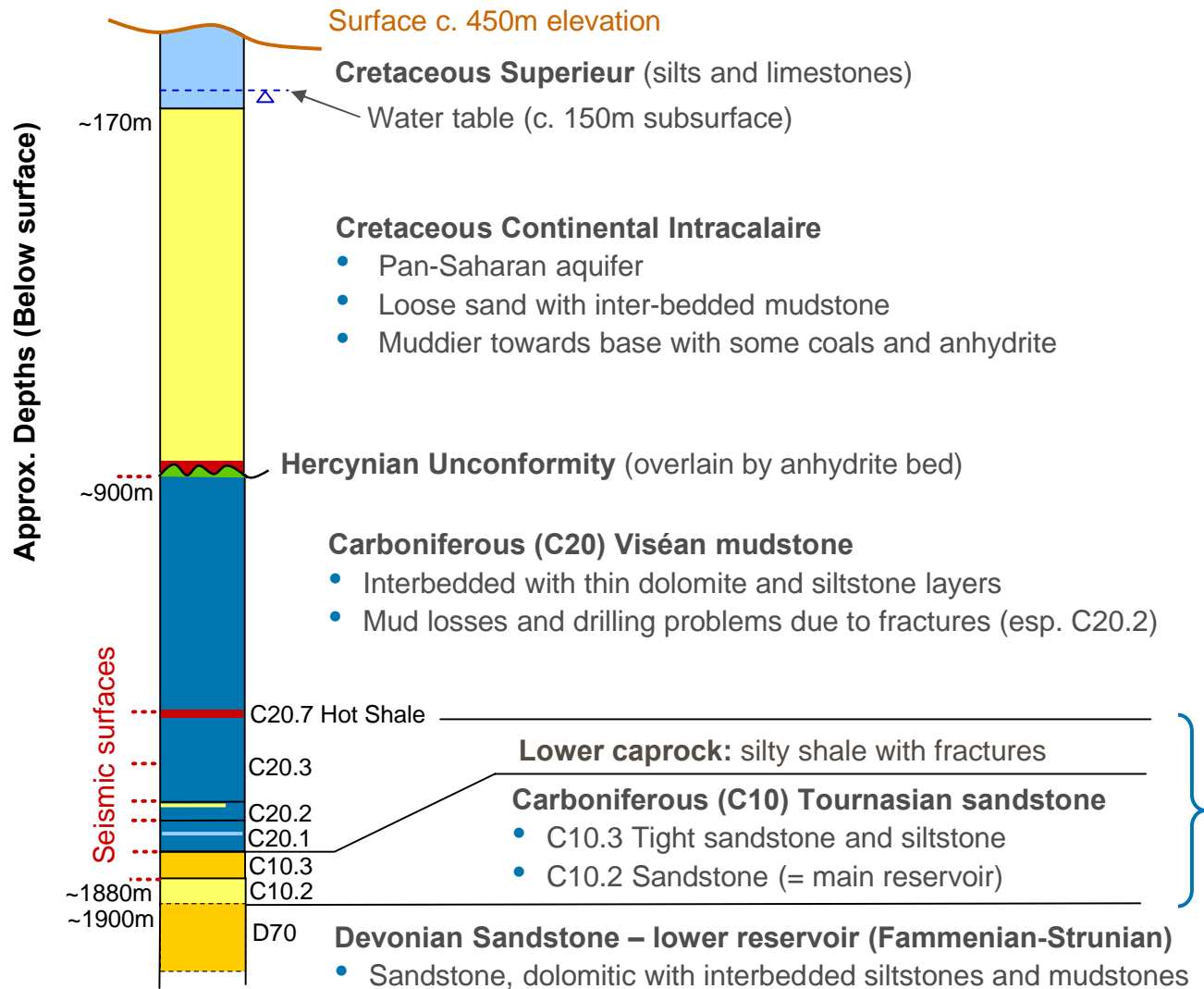

# InSAR & 4D Seismic Observations

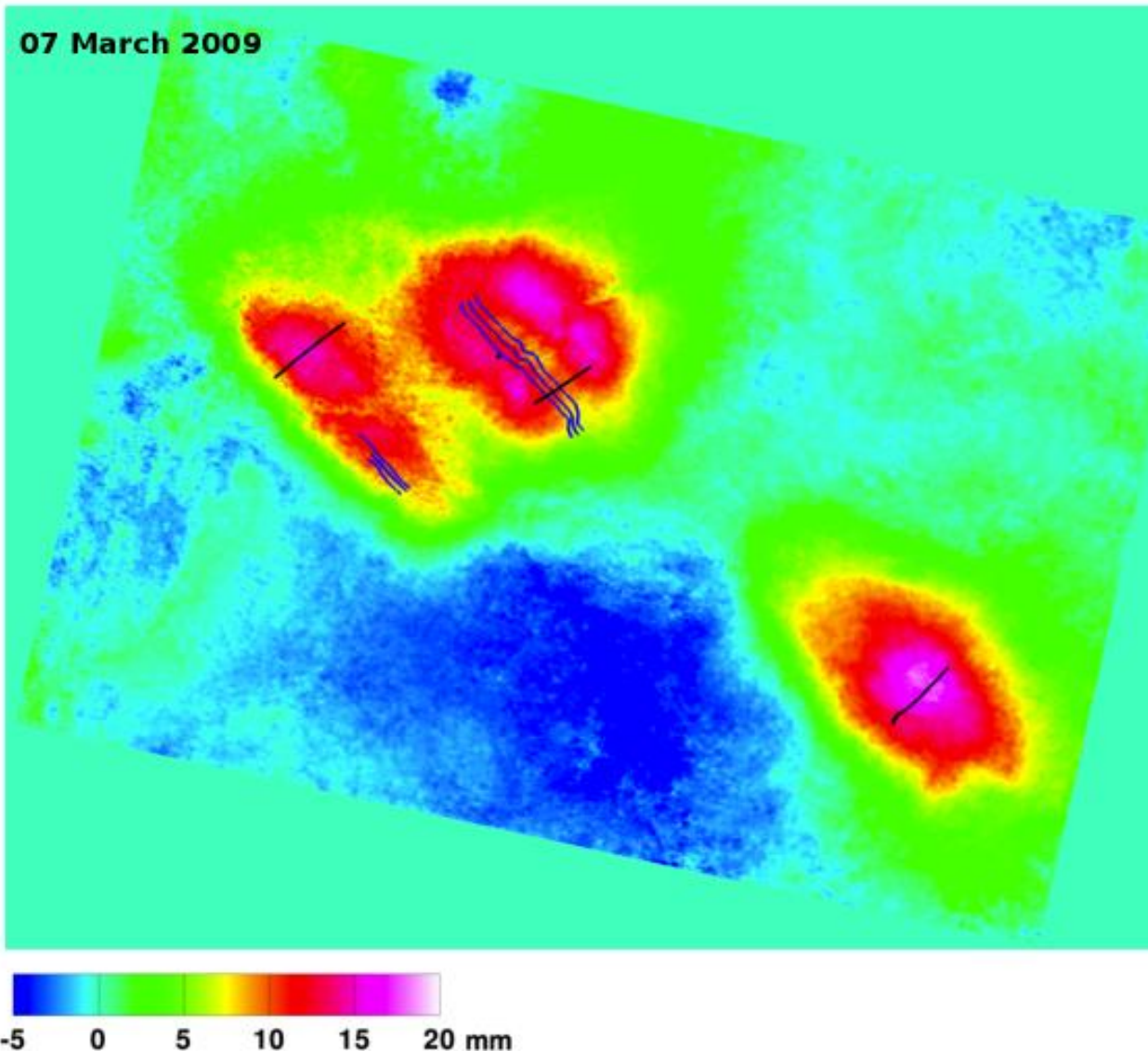

- InSAR uplift patterns provide indirect indication of pressure plume location, filtered through mechanical response of overburden.
- Anomalous double lobe feature suggests pressure may have migrated into lower caprock.
- Subsequent seismic observations seem to corroborate this hypothesis. Linear “pull-down” features evident.



# Damage-zone Hypothesis

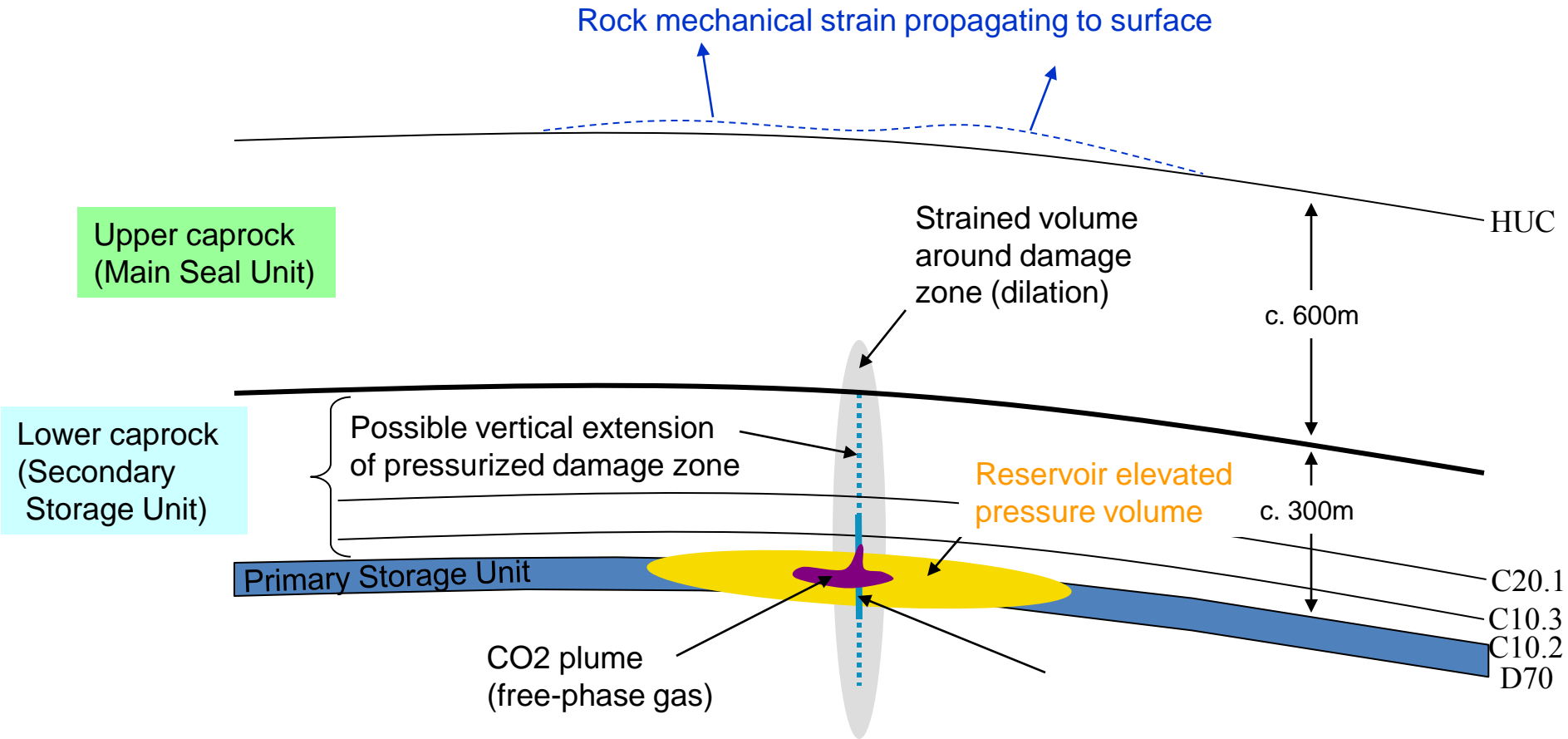

Schematic illustration of damage zone hypothesis [P. Ringrose].

# Key Questions

---

- Can we conclusively state the pressure and/or CO<sub>2</sub> is migrating up into lower caprock?
- What is the mechanism?
  - Hydrofracture
  - Pre-existing damage zone
  - Pre-existing fault
  - Some combination of the above
- Can we estimate the vertical extent of this feature?
- Can we extract more information from available monitoring data to constrain this problem?
- Would a leak to the shallow groundwater aquifer be detectable?

# Analytical Hydrofrac Analysis

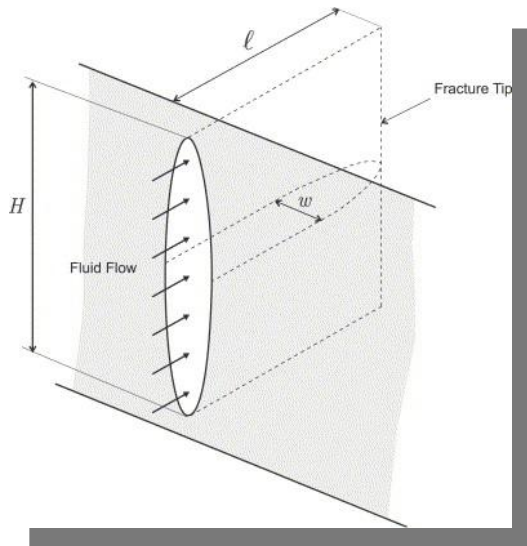
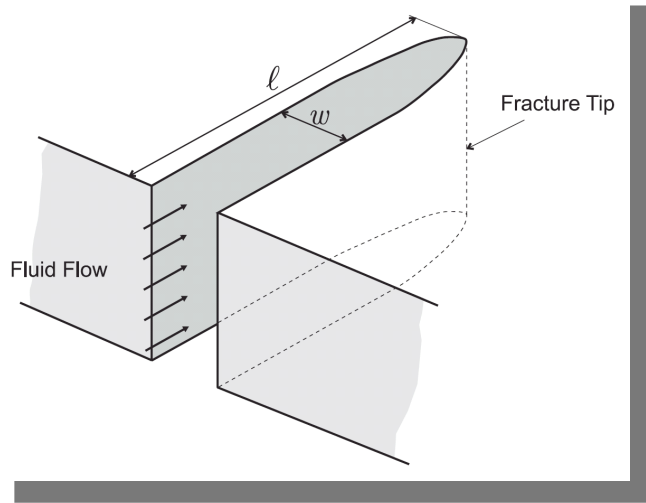

## Key Findings

- Analytical estimates of breakdown pressure agree with injection observations.
- Hydrofrac pressure was exceeded, and characteristic behavior observed in pressure/injection-rate behavior.
- Best estimate of vertical fracture extent is 200 meters, consistent with observations.

# Hydromechanical Modeling

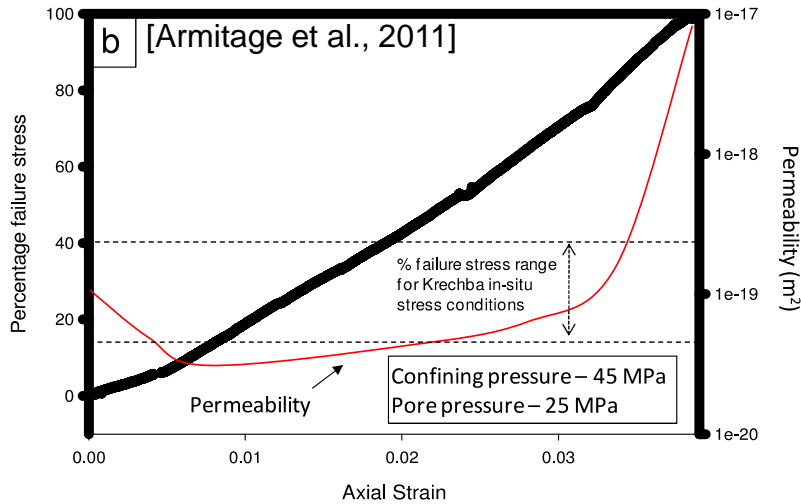

## Key Findings

- Several independent data sets suggest tensile, rather than shear, failure mechanisms.
- Tensile damage process is current favored hypothesis.

### InSAR Observations

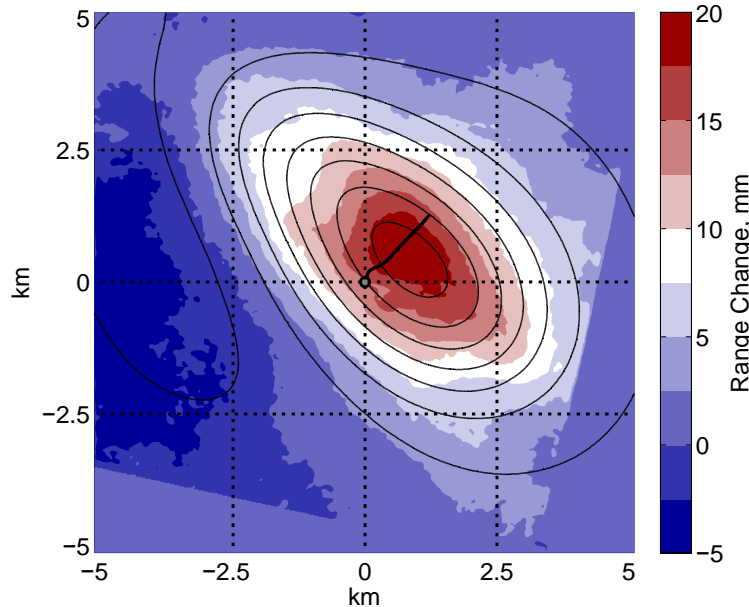

### Geocentric Model

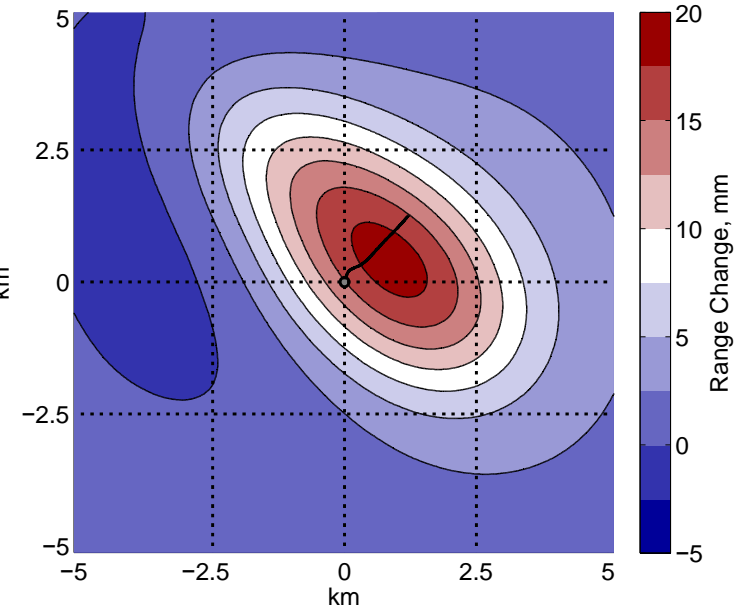

# Stochastic Inversion

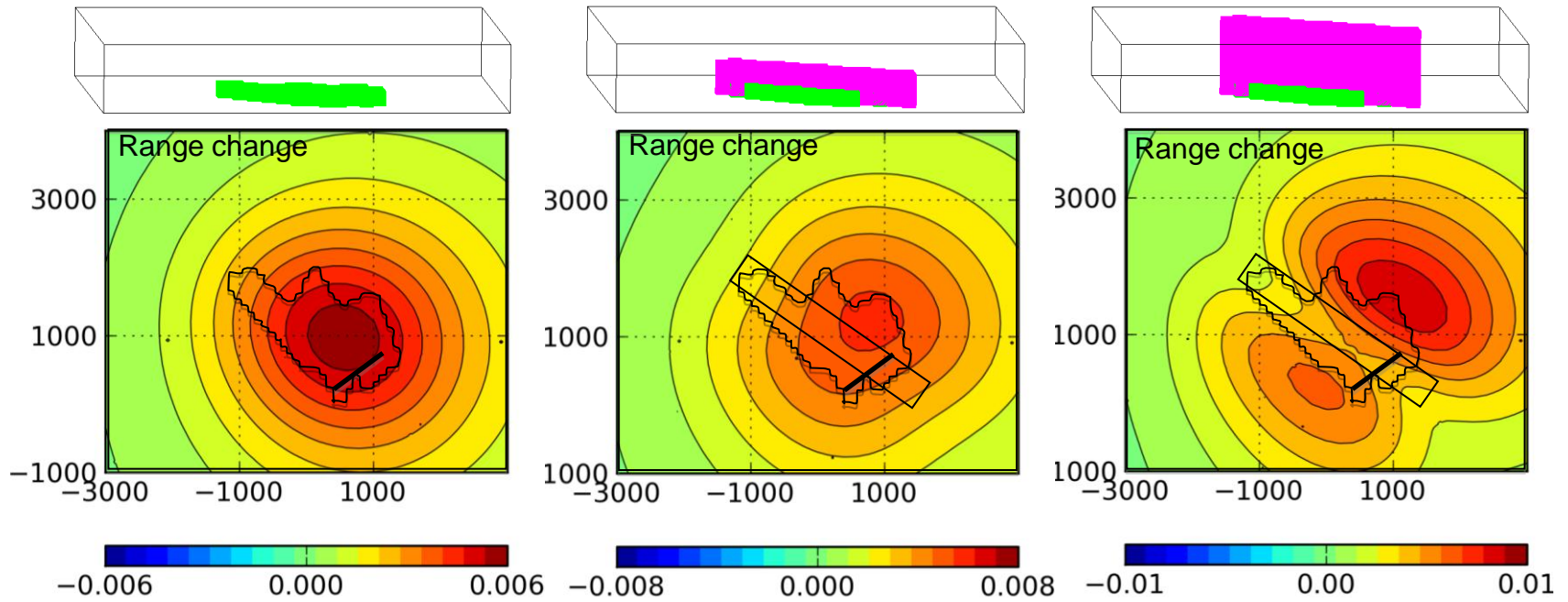

## Key Findings

- InSAR data indicative of tensile opening rather than volumetric dilation.
- Prediction of vertical extent of feature highly sensitive to overburden property model, which has significant uncertainty.
- Low probability that feature has grown beyond lower caprock interval.

# Summary & Accomplishments

---

- We have developed a series of analysis techniques, from simple to sophisticated, to guide the interpretation of available monitoring data sets.
- We have narrowed the range of viable hypotheses to explain the observed anomalies in the lower caprock.
- While there appears to be a low probability that the linear features extend beyond the lower storage unit, significant uncertainties remain in data analysis and interpretation.
- Significant work has also been devoted to understanding the geochemistry of the shallow aquifer should a leak occur (not discussed today).
- Future work is focused on extracting additional useful information by combining multiple data sets within the analyses.

# Appendix

---





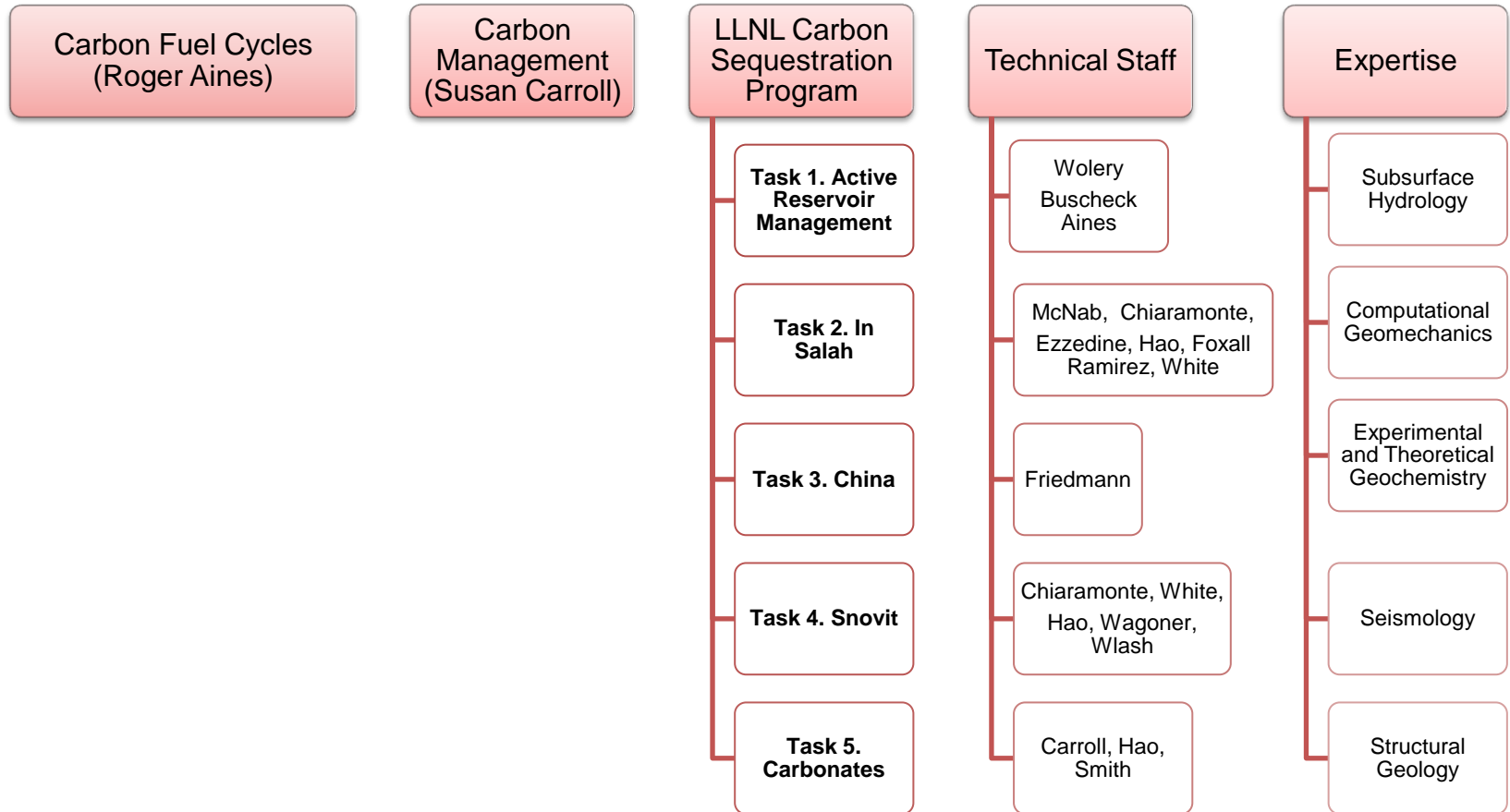





- Organization Chart
- Gantt Chart

# Organization Chart





# Gantt Chart

!"#\$	%& ( )	%& ( )'	%& ( )*
!'# \$ %&( ) *+, - ./01 .+23.*43506 - 7*+2(7+86 03- 828			
!'! 9'07*+, '(7.(2: - 5,(02			
!'! 23%7- 3.6 (750, - (, 6 (7(' 4			
!' 9*+801 .+>%/- 58- 07*- 6 (,' 54			

\$+, -

./ 0 12+3+
/ 45# 6+782+
7+2', +7
 9+ #3/ 4+

- Tasks 2.1, 2.2, and 2.4 are proceeding on schedule.
- Task 2.3 has been significantly delayed due to delays in receiving microseismic data. Field deployment of the initial microseismic array by the operator faced significant technical challenges, and had limited ability to locate microseismic events. These data acquisition issues are currently being addressed.